

FLOW X

TECHNICAL SPECIFICATION

ACCESS



FLOW X TECHNICAL SPECIFICATION

System details	
Speed	Max 0.15 m/s
Drive Type	Rack and pinion
Motor Wattage	350 W
Weight Capacity	125 kg (275lbs)
Automatic Stop	Yes
Staircase Incline	Up to 72°
Operation	Armrest detection and foldable joystick control as standard
Batteries	2 × 12V batteries, total 24V
Chair dimensions	
Footrest	Available in two sizes. Adjustable in 5 positions. Chair back to end of footrest: 720mm (short 620mm)
Seat height	Adjustable. 4 positions 515- 582.5mm from floor to top of the seat
Armrest	Width 613mm (straight position)

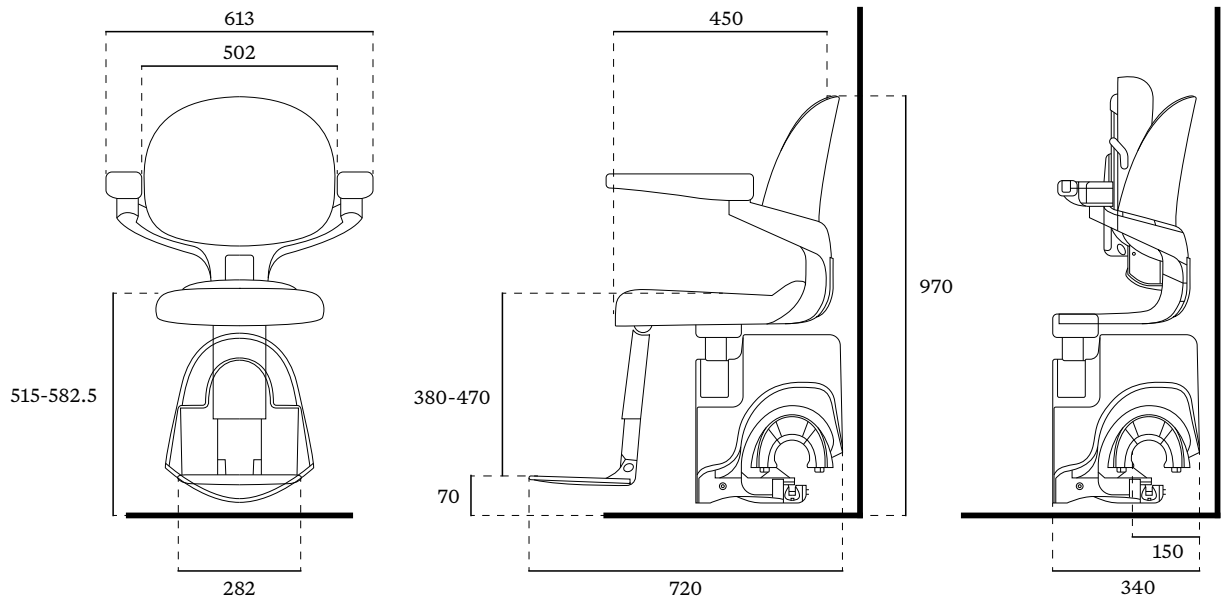

CHAIR

- Ergonomically designed chair with large backrest and seat for outstanding comfort.
- Unique automatic folding seat and footrest (optional).
- Pre-adjustable seat height (4 different positions).
- Upper surface of arms in anti-slip, soft-touch nylon.
- Patented swivel during travel (ASL technology).
- Footrest independent of drive (less knee flexion).
- Flame retardant PC-ABS material. Metal parts in durable epoxy powder coating.
- Easy-to-operate, foldable joystick.
- Weight capacity 125kg at +/- 72°.

DRIVE

- Cast aluminium motor frame with flame retardant ABS covers.
- Brushless main motor 24V DC, 3 phase 0.35 Kw.
- Soft start and soft stop.
- Microprocessor-controlled main motor and levelling system (SIL2).
- Batteries 2 × 12V, 7Ah.

FOOTREST

- Pre-adjustable footrest height (5 positions).
- Cast aluminium base including top TPE anti-slip surface.
- Linked seat and footrest.

SAFETY

- Armrest position detection.
- Retractable seatbelt with optional detection.
- Unique anti-squeeze safety sensors located under the seat.
- Safety covers protect the area between rail and motor.
- Overspeed control.
- Self-levelling control at +/- 5°.
- Emergency Lowering Button (electronic operation) located on the armrest.
- Call device in the armrest (communication module) providing two-way telephone communication (optional).
- Emergency stop button.

RAIL

- Maximum length of 35 metres.
- 80mm diameter rail.
- Epoxy powder coating in 4 standard RAL colours. Other RAL colours optional.
- Rail supports fixed to stairs and floors.
- Horizontal start, parking bends and vertical starts.
- Charge contacts on the rail, wiring hidden through the rail.
- Maximum angle of 72°.

CALL AND PARK

- Wall-mounted, with 3 colour status indicator LED's, operated by 4 x AAA batteries.